

543
Small articulated



543

FERRARI

PASSION FOR LIFTING

543 Technical data

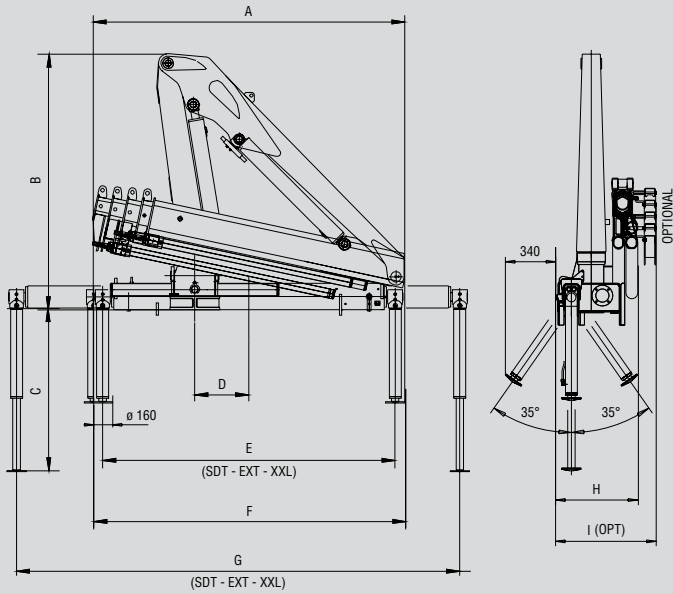

	A1	A2	A3	A4
A	2165	2165	2165	2165
B	1845	1845	1845	1845
C	1050	1050	1050	1050
D	380	380	380	380
E (STD - EXT)	1950	1950	1950	1950
E (XXL)	2010	2010	2010	2010
F	2170	2170	2170	2170
G (STD)	3040	3040	3040	3040
G (EXT)	4060	4060	4060	4060
G (XXL)	4780	4780	4780	4780
H	560	560	560	560
I	685	685	685	685

Model	kg	m	kg	m	kg	m	kg	m	kg	m
A1	3980*	1,00	1750**	2,20	995	3,86	770	4,98	550	6,44
A2	3820*	1,00	1650**	2,20	990	3,67	710	5,03	550	6,39
A3	3690*	1,00	1650**	2,20	930	3,77	650	5,13	500	6,49
A4	3480*	1,00	1580**	2,20	870	3,87	600	5,23	450	6,59
									360	7,95
									300	9,31
									240	10,77

*) Theoretical lifting capacity
 **) Capacity at fixed hook (only if with load limiting device in EC area)

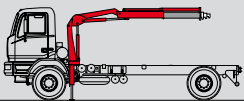

Recommended truck:
 G.V.W. ton 5,0

	Lifting Moment	Swiveling Angle	Working pressure	Oil tank capacity	Max Oil flow	Max lifting height	Standard crane weight
	tm	°	bar	l	l/min	m	kg
A1	3,98	380	235	35	16	7,82	710
A2	3,82	380	235	35	16	9,26	760
A3	3,69	380	235	35	16	10,65	810
A4	3,48	380	235	35	16	12,06	855

Standard

- Designed in accordance with EN12999+EN13849
- Design class: HC1-HD4
- High tensile strength steel
- Cross controls
- Hexagonal section extensions
- Independent extension cylinders
- Flanged valves
- Oil tank
- Assembly kit included
- Light indicator for correct stabilizer stowing (CE)
- Mechanical rotation limitation (CE)
- Fixed stabilizer cylinders with manual extension

Optional

- A CLASS - Crane Control System (CE)
- LED panel - Human Machine Interface (CE)



Fili FERRARI
 Via Einstein, 8
 42028 Poviglio (RE) Italy
 Tel. +39 0522/486308
 Fax +39 0522/486330
 info@filiferrari.it
 marketing@filiferrari.it
 www.filiferrari.com



Quality and environmental
 certified

Dealer

Data, descriptions, and illustrations pertain only and uniquely to models sold at the time of printing of this brochure. After the date of printing, this information is purely indicative and not binding upon Fili Ferrari. Future modifications are solely at the discretion of Fili Ferrari and are always in compliance with applicable and pertinent safety standards. To obtain updated data, descriptions, and illustrations, contact the manufacturer or your reseller. Cranes manufactured and/or marketed by Fili Ferrari.